

ЗАДАЧА 6. ЧЕТЫРЕХПОЛЮСНИКИ

Определить:

1. Коэффициенты четырехполосника:
A, B, C, D
2. Параметры схемы замещения
(T и П)

Таблица вариантов

Варианты	R=X Ом	Z ,Ом	Zm ,Ом	Z1 ,Ом
1	25	-	-	-
2	20	-	-	-
3	50	-	-	-
4	10	-	-	-
5	50	-	-	-
6	10	-	-	-
7	20	-	-	-
8	10	-	-	-
9	50	-	-	-
10	25	-	-	-
11	10	-	-	-
12	20	-	-	-
13	5	-	-	-
14	2,5	-	-	-
15	5	-	-	-
16	20	-	-	-
17	10	-	-	-
18	30	-	-	-
19	50	-	-	-

1.

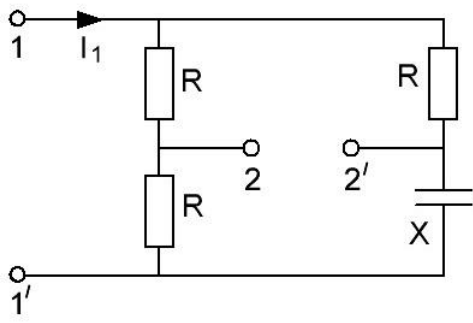

2.

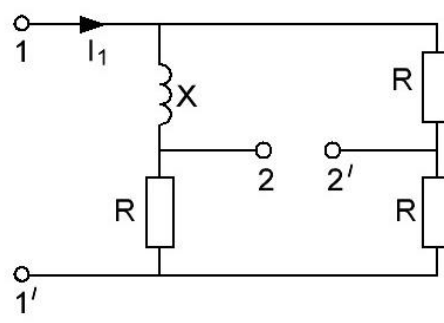

3.

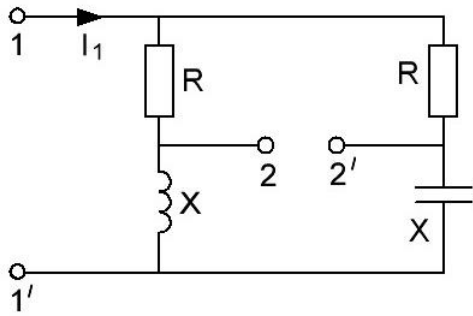

4.

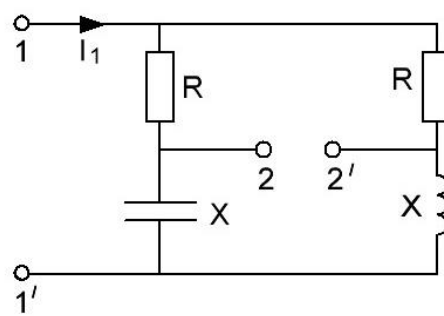

5.

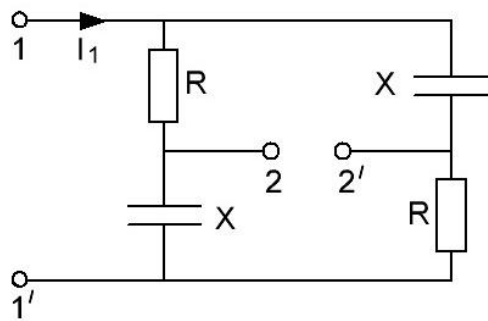

6.

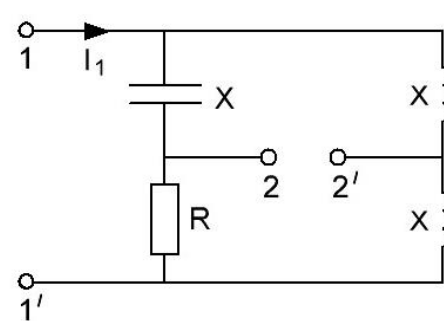

7.

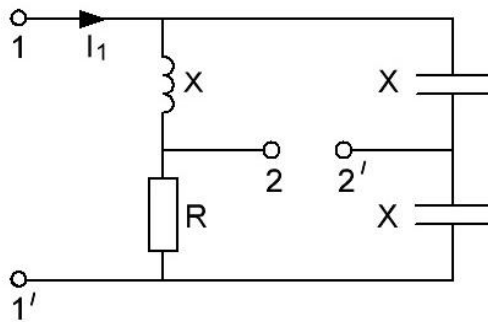

8.

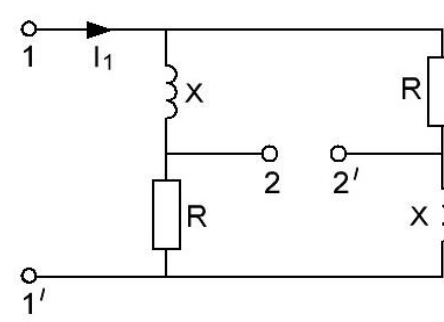

9.

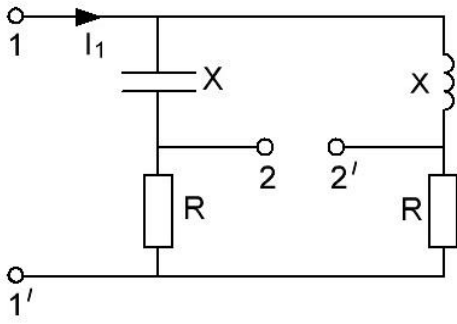

10.

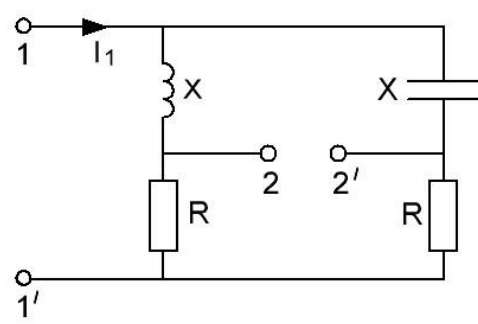

11.

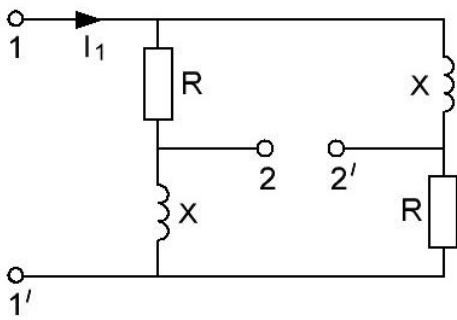

12.

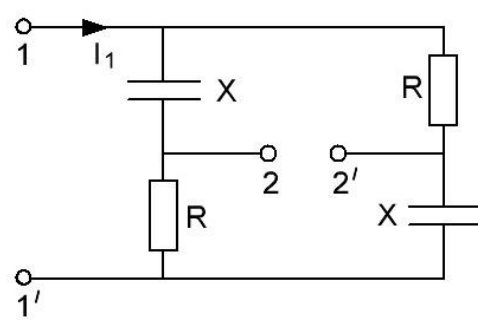

13.

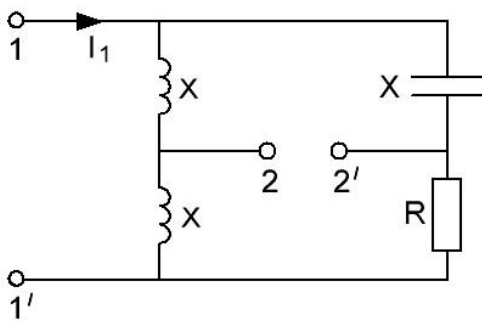

14.

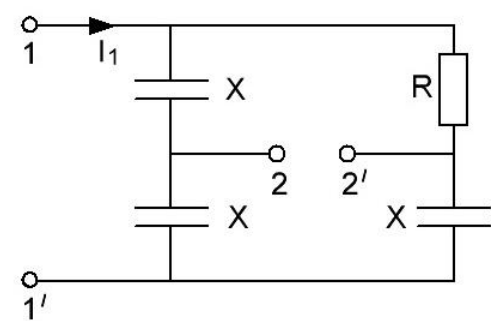

15.

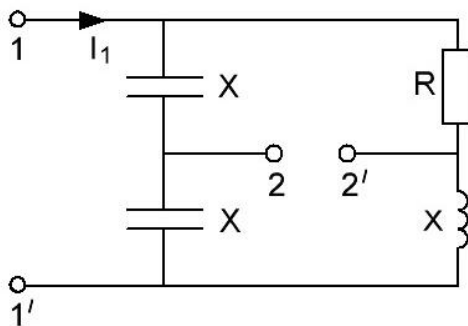

16.

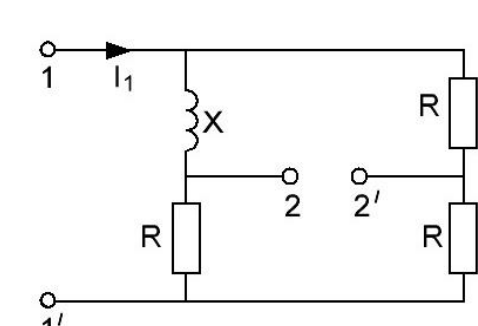

17.

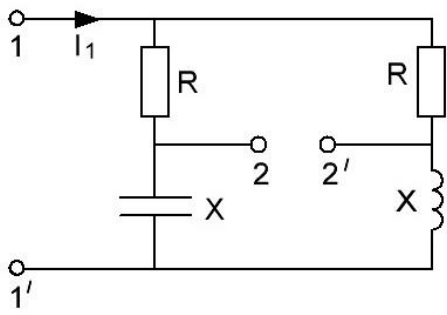

18.

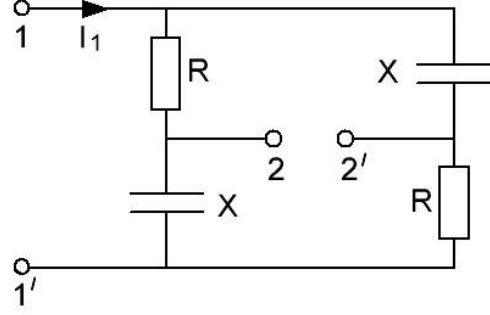

19.

